

OFFICE PAPER RECYCLING BIN : FOR MAXIMUM RESOURCE RECOVERY



EASY HANDLING
DURABLE CONSTRUCTION
ENVIRONMENTALLY-
RESPONSIBLE

Removable waste holder

- Fits neatly in place
- Simplifies daily waste disposal
- Optional bin liner easily fitted
- Ensures high quality paper recovery through lower contamination



Handles

- Moulded in handles for comfort
- Easy to carry for convenient use



Benefits

- Compact shape fits neatly under desk
- Provides for source separation of high quality paper
- Eliminates the need for 2 or more bins
- Waste holder reduces contamination
- Flat storage of paper allows greater recovery volume

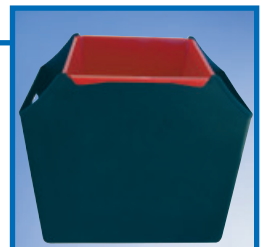

OFFICE PAPER RECYCLING

Material

OUTER BIN

■ Polymer components:

- Injection moulded from specially designed PP
- Resistant to decay, frost, heat and chemicals
- Special UV stabilisers provide excellent ageing characteristics

■ Long service life:

- High quality materials
- Most advanced manufacturing processes

■ Recycling:

- Minimum of 30% recycled content used in manufacturing
- All container parts are 100% recyclable

INNER BIN

■ Polymer components:

- Injection moulded from specially designed HDPE
- Resistant to decay, frost, heat and chemicals
- Special UV stabilisers provide excellent ageing characteristics

■ Long service life:

- High quality materials
- Most advanced manufacturing processes

■ Recycling:

- All container parts are 100% recyclable

Advantages

■ Easy handling:

- Practical handle for effortless emptying
- Light weight for easy movement
- Space saving for convenient use
- Eliminates the need for 2 or more bins
- Inner bin slots in place and easily lifts out for hygienic emptying
- Reduces contamination of recyclables
- Maximises paper recycling
- Waterproof, easily cleaned

Imprints and markings

- Individual markings with imprints or adhesive labels are available on request

SULO®

Sulo MGB Australia Pty Ltd
123 Wisemans Ferry Road
Somersby NSW 2250
AUSTRALIA
Telephone: +61 (0) 2 - 4348 8188
Facsimile: +61 (0) 2 - 4348 8128
Internet: www.sulo.com.au
E-mail: info@sulo.com.au

Sulo – Queensland Office
11 Argon Street
Sumner Park QLD 4070
AUSTRALIA
Telephone: +61 (0) 7 - 3725 5000
Facsimile: +61 (0) 7 - 3725 5099

Sulo – Victorian Office
6 Capital Link Drive
Campbellfield VIC 3061
AUSTRALIA
Telephone: +61 (0) 3 - 9357 7320
Facsimile: +61 (0) 3 - 9357 7340

Dimensions - Weights - Standards

- Nominal volume: Outer bin 13.5 litres
- Nominal volume: Inner bin 8.5 litres
- Net weight: 1.3kg
- Permitted total weight: 7.5 kg

measurements to be used as a guide only - variations will occur

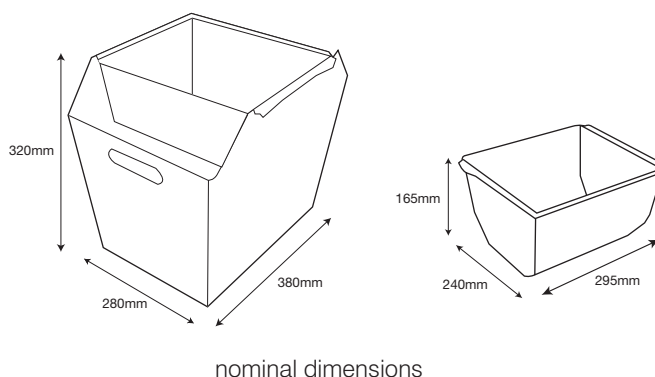

Colours

- Special colours including corporate colours for both outer and inner bins are available on request*
- Standard colours:
Outer bin: Black
Inner bin: Red, Black, Orange, Burgundy

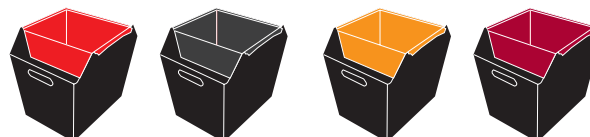

Additional products

- Organic waste containers
- Locks and slots on 2 and 4 wheel mobile garbage bins for secure document collection

If you require collection of waste paper phone Paper to Paper™ on 1300 727 377 to arrange your recycling collection service