

360 LITRE KOMPAKT CONTAINER: INCREASING YOUR CAPACITY TO RECYCLE



SUITABLE FOR ALL LIFTERS
PATENTED AUSTRALIAN
DESIGN

Designed for local market

- Patented design to suit Australian lifters
- Increased capacity in a compact foot print
- Manufactured in accordance with AS4123
- Dimensions of lifting zone similar to a 240 litre



Multiple applications

- Ideal for increased recycling needs
- Part of a multi bin system approach
- Assists in achieving waste minimisation goals
- Increased capacity aids in preventing leakage into the waste stream



Improved design features

- Patented hand grips for easy manoeuvring
- Textured finish on lifting columns for increased grip
- Foot step at rear aids in tilting the bin
- Easy grip handles for maximum comfort



360 LITRE KOMPAKT CONTAINER

Material

- **Polymer components:**
 - Injection moulded from specially designed HDPE
 - Resistant to decay, frost, heat and chemicals
 - Special UV – stabilisation provides excellent aging characteristics
- **Corrosion resistant steel axle**
- **Noise reduction**
 - Quiet - running solid rubber tyres
 - Tight fitting axle
- **Long service life**
 - Quality materials
 - Most advanced manufacturing processes
 - Withstands exposure to high mechanical stress levels
- **Recycling**
 - All container parts are recyclable

Advantages

- Australian design with improved column structure for grab lifting
- Textured lifting columns improve grip during lifting
- Rear foot step assists in tilting the bin for easy manoeuvring
- Patented hand grips allow for easy handling
- Ergonomic new look lid features optional ventilation
- Large area for customisation on both the body and lid
- Compatible with standard SULO components
- Dual axle housing provides maximum strength
- Compatible with identification and weighing systems
- Larger 250mm wheel for improved stability and easy handling
- Complies with performance standards of AS4123

Imprints and markings

- Manufacturer, year of manufacture, material
- Nominal volume, max permitted total weight
- AS4123 and EN840 markings
- No hot ashes or liquids standard lid insert
- Individual markings with imprints, multi colour print, hot-foil printing or adhesive labels*
- Customer specific serial numbers if required*

Quality

- Manufactured in accordance with AS4123 and DIN EN840

Dimensions - Weights - Standards

- Nominal volume: 360 litres
 - Net weight: approx 17 kg
 - Max load: 144 kg
 - Permitted total weight: 159 kg
- | | | |
|------------|-----------|-----------|
| ■ A 1100mm | ■ D 848mm | ■ G 650mm |
| ■ B 1028mm | ■ E 680mm | |
| ■ C 770mm | ■ F 520mm | |

Measurements to be used as a guide only – variations will occur

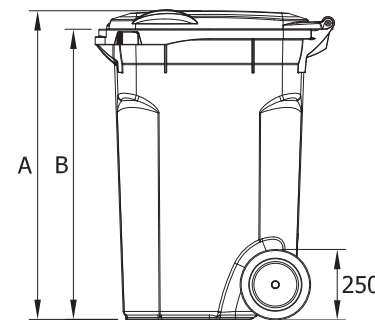
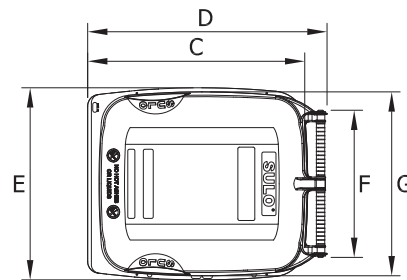

Colours

- Standard colours: black, nature green, dark green, grey
- Special colours are available on request* – common colours include blue, yellow, red



SULO MGB Australia Pty Ltd
123 Wisemans Ferry Road
Somersby NSW 2250
Australia
Tel: +61 (0) 2 - 4348 8188
Fax: +61 (0) 2 - 4348 8128
Internet: www.sulo.com.au
E-mail: info@sulo.com.au

SULO – Queensland Office
11 Argon Street
Sumner Park QLD 4074
Australia
Tel: +61 (0) 7 - 3725 5000
Fax: +61 (0) 7 - 3725 5099

SULO – Victorian Office
1950 Hume Hwy
Campbellfield VIC 3061
Australia
Tel: +61 (0) 3 - 9357 7320
Fax: +61 (0) 3 - 9357 7340

SULO - New Zealand
PO Box 58 962
Greenmount, Manukau City 2141
New Zealand
Tel: +64 9 - 968 2180
Fax: +64 9 - 968 2188