

120 LITRE CONTAINER: THE 'GO ANYWHERE - ALL PURPOSE' BIN



EASY HANDLING
VERSATILE
STABLE DESIGN

Adheres to all standards

- Built to EN Standards for MGBs
- Resistant to UV degradation (as per ISO 4892)
- Colour range to meet 'waste stream' standards



Multiple applications

- Part of a multi-bin system approach
- Organic or household waste
- Reduction of waste, diversion to recyclables



Improved design features

- Internal concave floor assists emptying
- Thicker handle for improved control
- Flexibility in bin and lid markings



120 Litre Container

Material

■ Polymer components:

- Injection moulded from specially designed HDPE
- Resistant to decay, frost, heat and chemicals
- Special UV-stabilisation provides excellent ageing characteristics

■ Corrosion resistant metal components:

- Solid, galvanised steel axle

■ Noise reduction:

- Quiet-running solid rubber tyres
- Tight-fitting axle

■ Long service life:

- High quality materials
- Most advanced manufacturing processes
- Withstands exposure to high mechanical stress levels

■ Recycling:

- All container parts are recyclable

Advantages

- Easy to manoeuvre
- Versatile, with a comprehensive accessories range
- Complies fully with EN or RAL quality requirements
- Open wheel case prevents accumulation of dirt
- Particularly stable due to external position of wheels
- Safe and easy to handle
- Suitable for all DIN lifting equipment
- Double angle rail for greater safety when emptying
- Compatible with identification and weighing systems
- Special ribs prevent containers from becoming jammed when stacked

Imprints and markings

- Manufacturer, year of manufacture, material
- Nominal volume, max permitted total weight
- EN 840, RAL markings
- Individual markings with imprints, screen printing, hot-foil printing or adhesive labels
- Customer specific serial numbers if required

Accessories

- For accessories and special design variations such as lid apertures, locks etc, please refer to the separate accessories sheet for 2-wheeled containers

Dimensions - Weights - Standards

■ Nominal volume:	120 litres				
■ Net weight:	approx 9.3 kg				
■ Max load:	48 kg				
■ Permitted total weight:	60 kg				
■ A	930 mm	■ D	545 mm	■ G	450 mm
■ B	870 mm	■ E	480 mm		
■ C	480 mm	■ F	345 mm		

Measurements to be used as a guide only – variations will occur

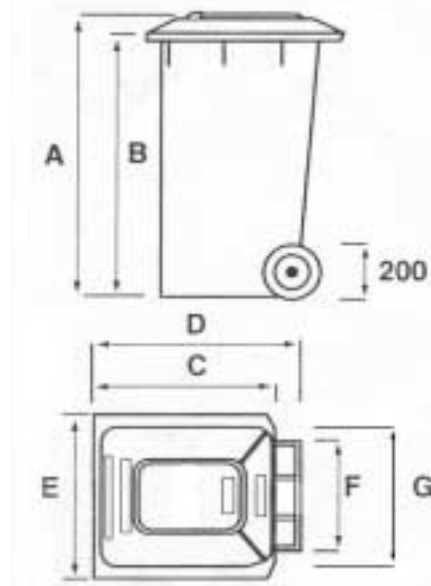

All dimensions and performance according to EN 840-1, 5 and 6

Colours

- Standard colours: nature green, dark green, grey
- Special colours are available on request – common colours include blue, yellow, red, brown, orange



SULO

Sulo MGB Australia Pty Ltd
123 Wisemans Ferry Road
Somersby NSW 2250
AUSTRALIA
Telephone: + 61 (0) 2 - 4348 8188
Facsimile: + 61 (0) 2 - 4348 8128
Internet: www.sulo.com.au
E-mail: info@sulo.com.au

Sulo – Queensland office
11 Argon Street
Sumner Park QLD 4074
AUSTRALIA
Telephone: + 61 (0) 7 - 3271 9800
Facsimile: + 61 (0) 7 - 3271 9813

Sulo – Victorian office
6 Capital Link Drive
Campbellfield VIC 3061
AUSTRALIA
Telephone: + 61 (0) 3 - 9357 7320
Facsimile: + 61 (0) 3 - 9357 7340