

## 1100 LITRE DOMED LID CONTAINER: SECOND GENERATION, FIRST CLASS



**UNIQUE DESIGN  
EASY HANDLING  
IMPROVED SAFETY**

### **Safety Handles**

- Easy grip handles on all sides
- Optimum manoeuvrability



### **Safety Trunnion**

- Increased stability
- Increased safety when lifting



### **Safety Lid**

- High degree of safety with integrated child safety device
- Closes automatically after emptying



# 1100 Litre Domed Lid Container

## Material

- Polymer components:
  - Injection moulded from specially designed HDPE
  - Resistant to decay, frost, heat and chemicals
  - Special UV-stabilisers provide excellent ageing characteristics
- Corrosion resistant steel components:
  - Wheel forks, wheel bearings, swivel brackets, lid retention springs and screws from galvanised steel. No maintenance necessary.
- Noise reduction:
  - Wheel assemblies with solid rubber tyres
- Long service life:
  - High quality materials
  - Excellent manufacturing processes
  - Withstands exposure to high mechanical stress levels
- Recycling:
  - All container parts are recyclable

## Design

### ADVANTAGES FOR THE USER:

- Easy to use lid, lockable, with adjustable spring support system
- High degree of safety - integrated child safety device prevents accidental closing of lid
- Versatile, with a comprehensive accessories range

### ADVANTAGES FOR THE COLLECTOR:

- Easy grip handles on all sides
- Safe, easy handling, even with heavy loads
- Wide lifting trunnions for improved safety during lifting, even with awkward loads
- Various wheel assembly configurations for different applications
- Water drainage plug as standard†
- Compatible with identification and weighing systems
- Domed lid with unique opening mechanism reduces wind problems during emptying

## Accessories

- For accessories and special design variations such as lid apertures, locks, towing brackets and fork lift sleeves, please refer to the separate accessories sheet for 4-wheeled containers

## Dimensions - Weights - Standards

- Nominal volume: 1100 litres
- Net weight: approx. 65 kg
- Max. load: 440 kg
- Permitted total weight: 510 kg

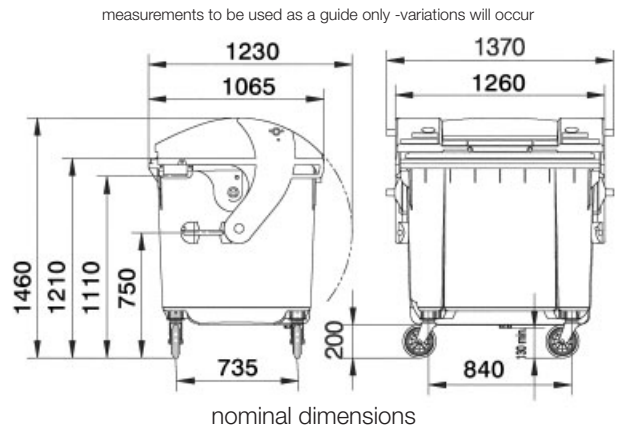

## Colours

- Standard colours: green, blue, yellow
- Special colours are available on request\*
- All additives are cadmium free and environmentally friendly



## Imprints and markings

- Manufacturer, year of manufacture, material
- Nominal volume, max. permitted total weight
- EN 840, RAL markings
- Individual markings with imprints, screen printing, hot-foil printing or adhesive labels available on request\*



Sulo MGB Australia Pty Ltd  
123 Wisemans Ferry Road  
Somersby NSW 2250  
AUSTRALIA

Telephone: +61 (0) 2 - 4348 8188  
Facsimile: +61 (0) 2 - 4348 8128  
Internet: [www.sulo.com.au](http://www.sulo.com.au)  
E-mail: [info@sulo.com.au](mailto:info@sulo.com.au)

Sulo – Queensland Office  
11 Argon Street  
Sumner Park QLD 4070  
AUSTRALIA

Telephone: +61 (0) 7 - 3725 5000  
Facsimile: +61 (0) 7 - 3725 5099

Sulo – Victorian Office  
6 Capital Link Drive  
Campbellfield VIC 3061  
AUSTRALIA

Telephone: +61 (0) 3 - 9357 7320  
Facsimile: +61 (0) 3 - 9357 7340